



USER MANUAL

EN

Edition: 2 from 21.02.2023

Supersedes edition: 1 from 03.07.2020

Power supplies AWZG2 series

Buffer power supply unit Grade 2.



Features:

- compliance with norm EN50131-6:2017 in grade 1, 2 and II environment class
- compliance with norm (KD) EN60839-11-2:2015+AC: standard and I environment class
- supply voltage ~230 V
- DC 13,8 V or 27,6 V uninterruptible power supply
- available versions with space for **7 Ah – 40 Ah** batteries
- available versions with current efficiencies:
 - **13,8 V: 2A/3A/5A**
 - **27,6 V: 2A/3A**
- microprocessor-based automation system
- dynamic battery test
- battery circuit continuity control
- battery voltage control
- battery fuse status control
- battery charging and maintenance control
- deep discharge battery protection (UVP)
- battery output protection against short circuit and reverse connection
- battery charging current jumper selectable
- START function of manual switch to battery power
- LED optical indication
- START facility for manual battery connection
- APS technical output indicating battery failure – OC type
- optional module AWZ639 changing OC outputs into relay outputs
- protections:
 - SCP short-circuit protection
 - OLP overload protection
 - against sabotage: unwanted enclosure opening
- warranty – 5 years from production date

Table of contents:

- 1. Technical description.**
 - 1.1. General description**
 - 1.2. Block diagram**
 - 1.3. Description of components and connectors**
 - 1.4. Specifications**
- 2. Installation.**
 - 2.1. Requirements**
 - 2.2. Installation procedure**
- 3. Operating status indication.**
 - 3.1. Optical indication**
 - 3.2. Technical outputs**
 - 3.3. Technical outputs – relay.**
 - 3.4. Standby time**
 - 3.5. Battery charging time**
 - 3.6. Running PSU on battery backup**
- 4. Operation and use.**
 - 4.1. Overload or short circuit of the PSU output (SCP on)**
 - 4.2. Dynamic battery test**
 - 4.3. Maintenance.**

1. Technical description.**1.1. General description.**

The buffer power supply is designed in accordance with the requirements of the (I&HAS) EN50131-6:2017 grade 1,2, II environmental class and EN60839-11-2:2015+AC:2015, I environmental class. The power supplies units are intended for for an uninterrupted supply of I&HAS and KD devices requiring stabilized voltage of 12 V or 24 V DC ($\pm 15\%$).

Displaying parameters of the power supply:

PSU's name	Output voltage	Charging current	Output current	Total output current with charging
			Output current for grade 1, 2 EN50131-6	
AWZG2-12V2A-B	13,8 V	0,2 / 0,5 A	0,58 A	2 A
AWZG2-12V3A-C		0,5 / 1 A	1,41 A	3 A
AWZG2-12V5A-C		0,5 / 1 / 2 A	1,41 A	5 A
AWZG2-12V5A-D		0,5 / 1 / 2 A	3,33 A	5 A
AWZG2-24V2A-B	27,6 V	0,5 / 1 A	0,58 A	2 A
AWZG2-24V3A-C		0,5 / 1 A	1,41 A	3 A

In case of power failure, a battery back-up is activated immediately.. The PSU is housed in a metal enclosure (colour RAL 9003) which can accommodate a battery. A micro switch indicates door opening (front cover).

Depending on a required protection level of the alarm system in the installation place, the PSU efficiency and the battery charging current should be set as follows:

Grade 1, 2 - standby time 12h:

The 12h standby output current can be calculated from the formula:

$$I = Q_{AKU} / 12 - I_z$$

where:

Q_{AKU} – minimum battery capacity [Ah]

I_z – PSU current consumption (including optional modules) [A] (Table 4).



Power supply should be configured to work in intruder alarm systems or access control, depending on application. For this purpose, appropriate charging current should be selected (taking into account battery capacity and required charging time).

1.2. Block diagram (fig.1).

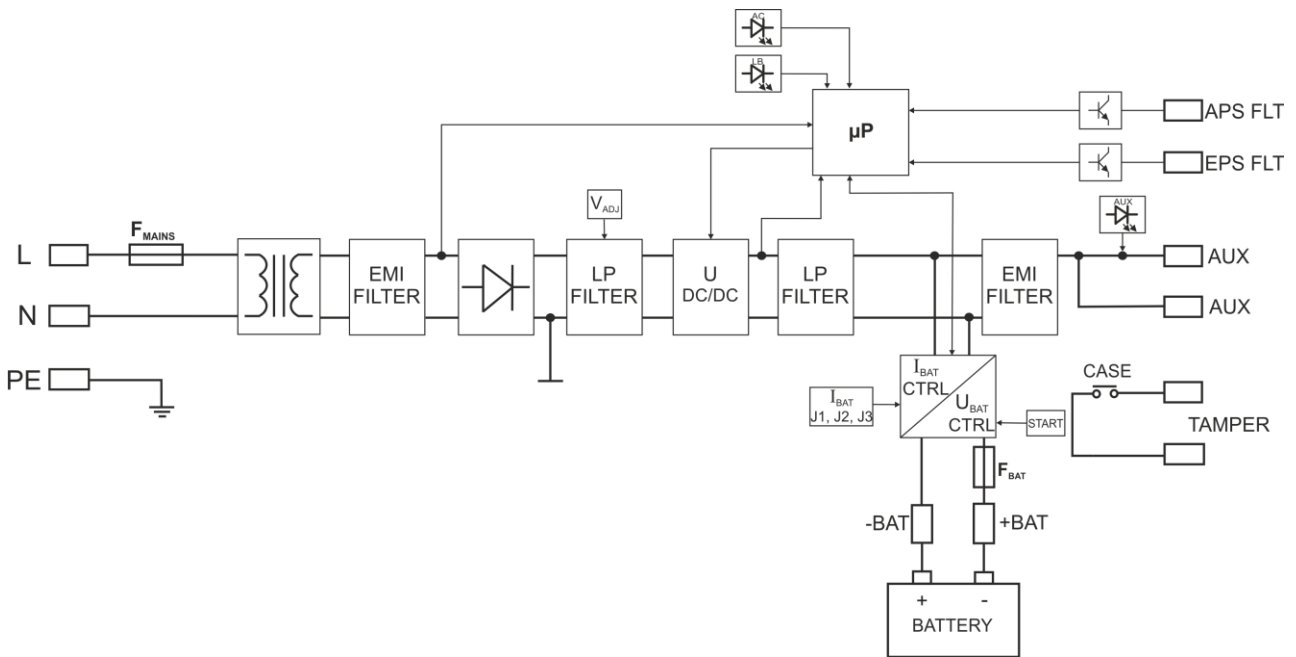

Fig.1. Block diagram of PSU.

1.3. Description of components and connectors.

Table 1. Elements of PSU pcb (see: tab. 2a,b,c).

Element no.	Description
①	START button (launching from battery)
②	V_{ADJ} potentiometer, adjustable output voltage
③	F_{BAT} fuse in the battery circuit
④	<p>Terminals:</p> <p>~AC~ – AC power input</p> <p>EPS – technical output of AC power loss indication hi-Z state = AC power failure 0V state = AC power - O.K.</p> <p>APS – technical output of battery failure hi-Z state = failure 0V state = PSU status O.K.</p> <p>+BAT- – terminals for battery connection</p> <p>+AUX- – DC power supply output, (+AUX= +U, -AUX=GND)</p> <p>Description: hi-Z – high impedance, 0V – connection to the ground GND</p>

5	LEDs – AC – indication of presence of main power
6	LEDs – AUX – power supply output voltage indication
7	LEDs – LB – battery charging indication
8	Connector to the external LED indicators
9	<p>Jumper I_{BAT}; – battery charging current configuration</p> <p>Power supply unit 12V2A (see Fig 2a)</p> <ul style="list-style-type: none"> • I_{BAT} = , I_{BAT} = 0,2 A • I_{BAT} = , I_{BAT} = 0,5 A <p>Power supply unit 12V3A / 24V2A (see Fig 2b)</p> <ul style="list-style-type: none"> • I_{BAT} = , I_{BAT} = 0,5, A • I_{BAT} = , I_{BAT} = 1,0 A <p>Power supply unit 12V5A (see Fig 2c)</p> <ul style="list-style-type: none"> • J1= J2= J3= I_{BAT} = 0,5A • J1= J2= J3= I_{BAT} = 1A • J1= J2= J3= I_{BAT} = 2A <p>Power supply unit 24V3A (see Fig 2c)</p> <ul style="list-style-type: none"> • I_{BAT} = , I_{BAT} = 0,5, A • I_{BAT} = , I_{BAT} = 1,0 A <p>Description: jumper installed, jumper removed</p>

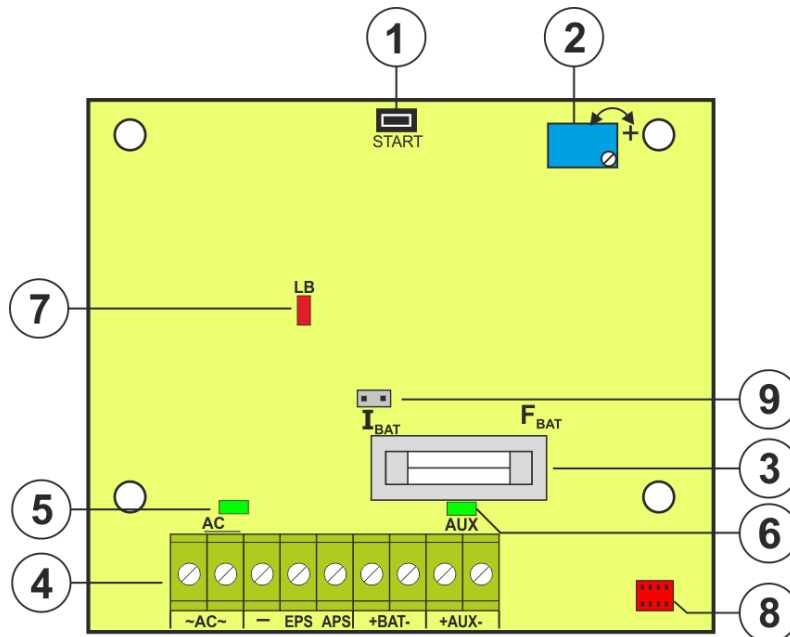

Fig. 2a. View of PCB board of 12V2A model

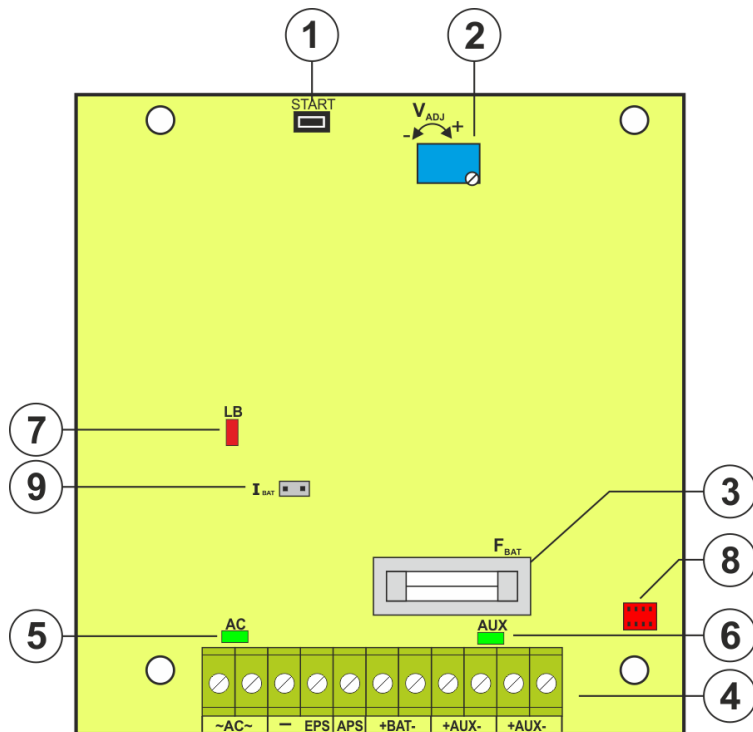

Fig. 2b. View of PCB board of 12V3A / 24V2A model

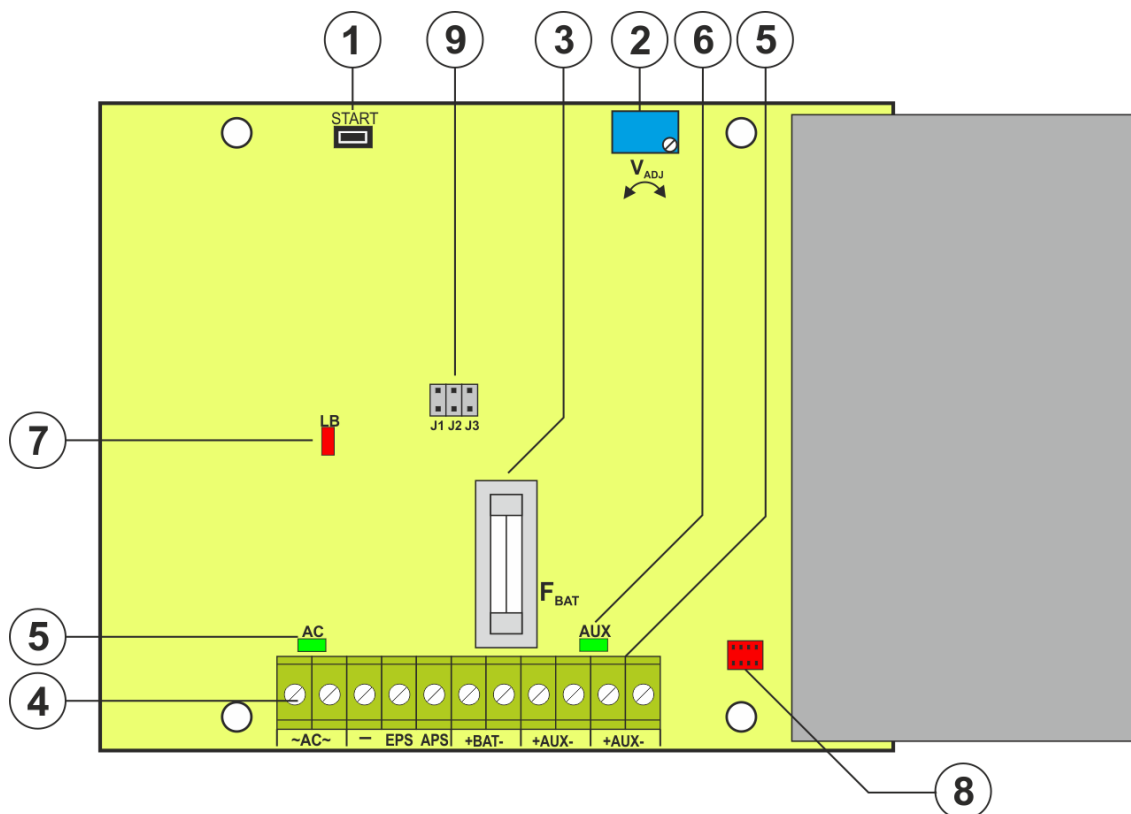



Fig. 2c. View of PCB board of 12V5A / 24V3A model

Table 2. Elements of PSU (see: tab. 3).

Element no.	Description
①	Isolation transformer
②	PCB of the PSU (Tab. 1, Fig. 2)
③	TAMPER; micro switch of tamper protection (NC)
④	L-N 230 V power supply connector,  protection connector
⑤	F _{MAINS} fuse in the battery circuit 230 V
⑥	Battery connectors +BAT = red, - BAT = black

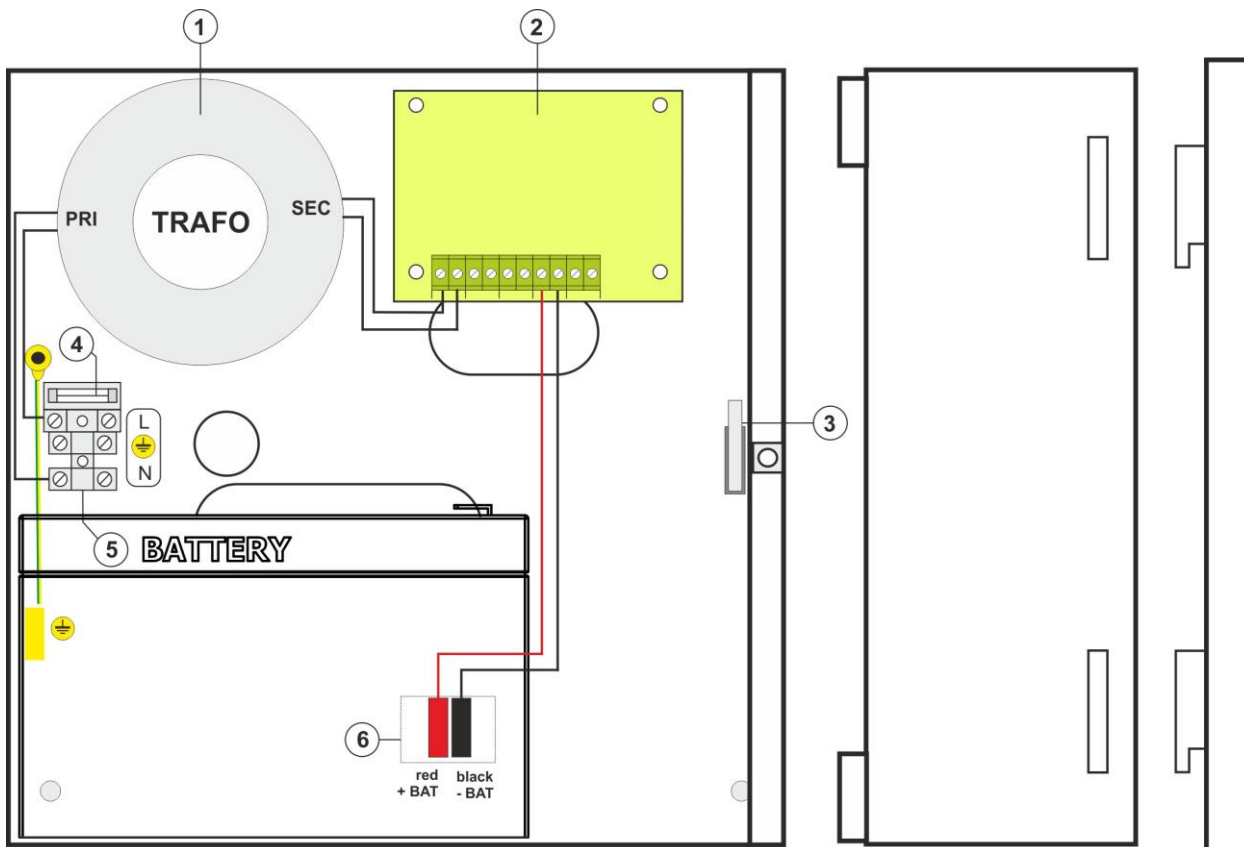

Fig.3. View of PSU.

1.4. Specifications:

- electrical specifications (tab. 3)
- mechanical specifications (tab. 4)
- operation safety (tab. 5)
- operating specifications (tab. 6)

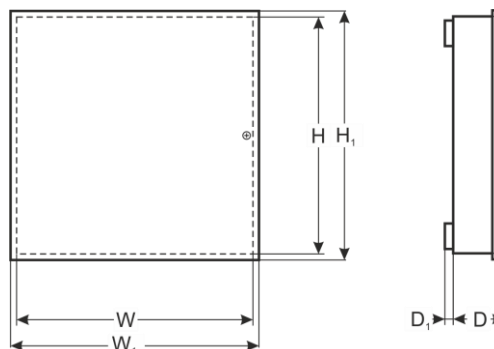

Table 3. Electrical parameters.

Models	AWZG2-12V2A	AWZG2-12V3A	AWZG2-12V5A	AWZG2-24V2A	AWZG2-24V3A
PSU type EN50131-6	A, Grade 1,2, II environmental class				
Supply voltage	~ 230 V				
Current consumption	0,23 A	0,4 A	0,6 A	0,45 A	0,7 A
Power frequency	50 Hz				
Output power PSU	27 W	41 W	69 W	55 W	83 W
Total output current with charging	2 A	3 A	5 A	2 A	3 A
Efficiency	76%	72%	77%	81%	83%
Output voltage	11 - 13,8 V – buffer operation 10 - 13,8 V – battery-assisted operation			22 - 27,6 V – buffer operation 20 - 27,6 V – battery-assisted operation	
Voltage adjustment range	13 - 14 V			27-28 V	
Ripple voltage (max.)	10 mV p-p	45 mV p-p	30 mV p-p	55 mV p-p	55 mV p-p
Current consumption by the PSU systems during battery-assisted operation	11 mA	10 mA	11 mA	14 mA	14 mA
Low battery voltage indication	Ubat < 11,5 V, during battery operation			Ubat < 23 V, during battery operation	
Charging current (jumper selectable)	0,2/0,5A	0,5/1A	0,5/1/2A	0,5/1A	0,5/1A

Battery circuit protection SCP and reverse polarity connection	- F _{BAT} fuse (in case of a failure, fuse-element replacement required)				
Deep discharge battery protection UVP	U<10 V (± 0,5V) – disconnection of battery terminal		U<20 V (± 0,5V) – disconnection of battery terminal		
Optical indication	- LEDs on PCB of power supply unit - LED indicators on power supply's cover (see section 3.1)				
Technical outputs:	- OC type: 50mA max. normal status: L (0V) level, failure: hi-Z level				
- EPS; output indicating AC power failure - APS; output indicating battery failure	- OC type: 50mA max. normal status: L (0V) level, failure: hi-Z level				
Tamper protection: - TAMPER indicates enclosure opening	- microswitch, NC contacts (enclosure closed), 0,5 A@50 V DC (max.)				
Fuses: - F _{MAINS} - F _{BAT}	T 500mA/250V F 3,15A/250V	T 630mA/250V F 5A/250V	T 1A / 250V T 6,3A/250V	T 1A/250V F 5A/250V	T 3,15A / 250V T 6,3A/250V
Terminals: Mains supply: Outputs: Battery outputs: TAMPER:	Φ0,51±2 (AWG 24-12) Outputs: Φ0,41±1,63 (AWG 26-14)				
	6,3F-0,5, 22cm	6,3F-0,5, 22cm	Φ6 (M6-1,5), 35cm	6,3F-0,5, 22cm	6,3F-0,5, 30cm
	wires, 40cm				
Notes	Convexional cooling				

Table 4. Mechanical parameters

	AWZG2-12V2A-B	AWZG2-12V3A-C	AWZG2-12V5A-C	AWZG2-12V5A-D	AWZG2-24V2A-B	AWZG2-24V3A-C
Enclosure dimensions (W ₁ xH ₁ xD ₁ +D) [±2mm]	205x237x82+8	235x305x82+8	305x305x105+8	335x385x173+14	205x305x82+8	335x385x173+14
Fixing (WxH)	175x202	205x272	274x265	298x310	205x272	298x310
Space for battery (WxHxD)	190x100x75	215x172x75	250x172x100	325x178x175	215x172x75	325x178x175
Fitting battery, type	7-9 Ah (SLA)	17-20 Ah (SLA)	17-20 Ah (SLA)	28Ah-40 Ah (SLA)	2x 7-9 Ah (SLA)	2x 17-20 Ah (SLA)
Enclosure	steel sheet DC01 0,7mm			steel sheet DC01 1mm	steel sheet DC01 1mm	steel sheet DC01 1mm
Closing	Cheese head screw (at the front), (lock assembly possible)					
Net/gross weight	2,13/2,25 kg	2,84/2,94 kg	3,74/3,87 kg	6,07/6,67 kg	3,14/3,24 kg	6,5/7,1 kg
Notes	Enclosure does not adjoin assembly surface so that cables can be led..					

Table 5. Operation safety.

Protection class EN 62368-1	I (first)
Protection grade EN 60529	IP20
Electrical strength of insulation: - between input and output circuits of PSU - between input circuit and protection circuit - between output circuit and protection circuit	4000 V DC min. 2500 V DC min. 500 V DC min.
Insulation resistance: - between input circuit and output or protection circuit	100 MΩ, 500 V DC

Table 6. Operating parameters.

Environment class EN 50131-6	II
Environment class EN 60839-11-2	I (first)
Operating temperature	-10°C...+40°C
Storage temperature	-20°C...+60°C

Relative humidity	20%...90%, without condensation
Vibrations during operation	unacceptable
Impulse waves during operation	unacceptable
Direct insulation	unacceptable
Vibrations and impulse waves during transport	According to PN-83/T-42106

2. Installation.

2.1. Requirements.

The buffer PSU is to be mounted by a qualified installer, holding relevant permits and licenses (applicable and required for a given country) for 230 V interference and low-voltage installations. The unit should be mounted in confined spaces with normal relative humidity (RH=90% maximum, without condensing) and temperature from -10°C do +40°C. The PSU shall work in a vertical position that guarantees sufficient convectional air-flow through ventilating holes of the enclosure.

As the PSU is designed for a continuous operation and is not equipped with a power-switch, therefore an appropriate overload protection shall be guaranteed in the power supply circuit. Moreover, the user shall be informed about the method of unplugging (usually through assigning an appropriate fuse in the fuse-box). The electrical system shall follow valid standards and regulations.

2.2. Installation procedure.



CAUTION!

Before installation, make sure that the voltage in the 230 V power-supply circuit is cut off. To switch off power use an external switch in which the distance between the contacts of all poles in the disconnection state is not less than 3mm.

It is required to install an installation switch with a nominal current of min. 6 A in the power supply circuits outside the power supply unit.

1. Mount the PSU in a selected location and connect the wires.
2. Connect the power cables (~230 V) to AC 230 V clips of the transformer. Connect the ground wire to the clip marked by the earth symbol \oplus . Use a three-core cable (with a yellow and green \oplus protection wire) to make the connection. Lead the cables to the appropriate clips of the sub plate through the insulating bushing. Wires should be deisolated to a length of 7mm.

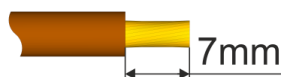

The shock protection circuit shall be performed with a particular care, i.e. the yellow and green wire coat of the power cable shall stick to one side of the ' \oplus ' terminal - in the PSU enclosure. Operation of the PSU without a properly made and fully operational shock protection circuit is UNACCEPTABLE! It can cause a device failure or an electric shock.

3. Connect the receivers' cables to the +AUX, -AUX connectors of the terminal block on the PSU board.
4. If needed, connect the device cables to the technical outputs:
 - EPS; technical output indicating AC power failure
 - APS; technical output indicating battery failure
 - optional installation of the AWZ639 relay module changing technical outputs of the OC type to relay type (page. 10, section. 3.3)
5. Use the I_{BAT} jumper to set the maximum battery charging current, taking into account the battery parameters and required charging time.
6. Mount the battery in the battery compartment of the enclosure (Fig. 3). Connect the batteries with the PSU paying special attention to the correct polarity and type of connections (Fig.4):

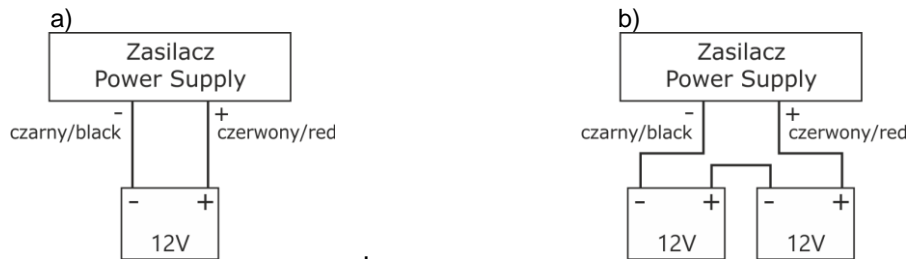

Fig. 4 Connecting batteries depending on voltage version of power supply:
a) version 12V, b) version 24V,

- Switch on 230 V supply. Green AUX and yellow LB LEDs on power supply PCB should be ON while charging battery.

Output voltage of the PSU, without load $U = 13,8 \text{ V DC}$ (or $27,6 \text{ V DC}$).

During battery charge, voltage can amount to $U = 11 - 13,8 \text{ V DC}$ (or $22 - 27,6 \text{ V DC}$).

- Run the PSU test: check the LED (Tab. 7), technical output; through:
 - **cutting off the 230 V current:** LED AC (Fig. 2 level 5), EPS technical output after time 30s
 - **battery disconnection:** optical indication, APS technical output – after a battery test have been completed (~5min).
- After installing and checking proper working, the enclosure can be closed.

3. Operating status indication.

The power supply unit features LED status indication. PSU status can be remote-controlled by two technical outputs.

3.1. Optical indication.

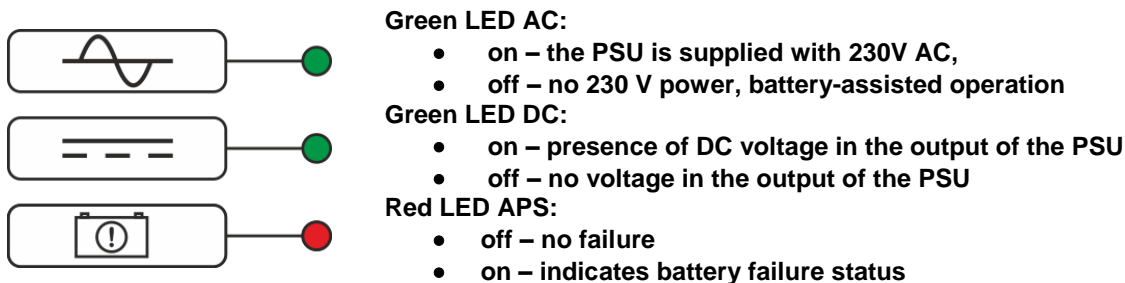

Additionally, PSU is fitted with 3 LED lights indicating operating status: AC, LB and AUX at the PCB of PSU:

- **AC – green LED:** under normal status (AC supply) the diode is permanently illuminated. The absence of AC supply is indicated by the AC diode going off..
- **LB – red LED:** indicates the battery charging process
- **AUX – green LED:** indicates the DC supply status in the output of the PSU module. Under normal status, the diode is permanently illuminated and in case of a short-circuit or overload, the diode goes off..

3.2. Technical outputs.

The PSU is equipped with indication outputs:

- **EPS FLT - technical output indicating 230 V power failure.**

The output indicates 230 V power failure. Under normal status – with the 230 V supply on, the output is shorted to ground GND. In case of power failure, the PSU will switch the output into hi-Z high impedance state after a time about 30s.

- **APS FLT - output indicating battery failure.**

The output indicates the PSU failure. The output indicates failure PSU module. Under normal status (correct operation) the output is shorted to ground GND. If there is failure, the output is switched into hi-Z high impedance state.

PSU failure can be caused by the following events:

- defective or low battery
- battery fuse failure
- no continuity in the battery circuit
- battery voltage below 11,5 (23) V during battery-assisted operation

A battery failure is detected within a maximum of 5 minutes - after each battery test



After switching from battery operation to electrical network operation, battery failure indication is inactive until full recharge battery, or for 24 hours after power returns.

The power supply technical outputs are open collector (OC) type, as shown schematically below.

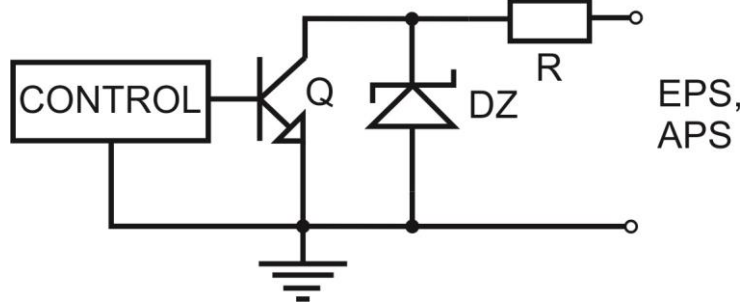

Fig. 4. Electrical diagram of OC outputs.

3.3. Technical outputs – relay.

If the OC type outputs are not sufficient to control the unit, it is possible to use the AWZ639 relay module changing technical outputs of the OC type to relay type.

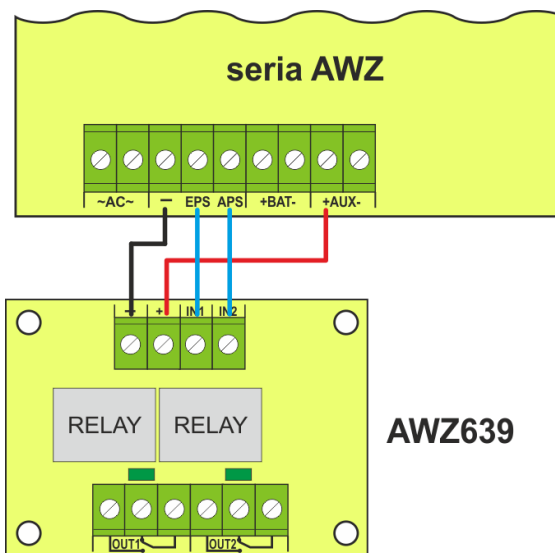

Fig. 5. The diagram of connecting the AWZ639 module.

3.4. Standby time.

Battery-assisted operating depends on battery capacity, charging level and load current. To maintain an appropriate standby time, current drawn from the PSU in battery mode should be limited:

PSU's name	Output current max.	Output current (in standby mode for grade 2 EN50131-6, EN60839-11)
AWZG2-12V2A-B	2 A	0,58A
AWZG2-12V3A-C	3 A	1,41A
AWZG2-12V5A-C	5 A	1,41A
AWZG2-12V5A-D	5 A	3,33A
AWZG2-24V2A-B	2 A	0,58A
AWZG2-24V3A-C	3 A	1,41A

Total current of the receivers + battery charging current mustn't cross maximum current of power supply

3.5. Battery charging time.

The PSU has a battery circuit charged with direct current. The current selection is done with use of the I_{BAT} jumpers. The table below shows how long does it take to charge a (fully discharged) battery up to min. 80% of its nominal capacity.

Table 9. Battery charging time up to the capacity of 0,8.

Battery	Charging current			
	0,2A	0,5A	1A	2A
7Ah - 9Ah	32h - 36h	13h - 15h	-	-
17Ah - 20Ah	-	28h - 32h	14h - 16h	-
28Ah	-	-	23h	12h
40Ah	-	-	36h	18h

3.6. Running PSU on battery backup.

Power supply allows you to run on battery backup when necessary. To do this, press the START button on PCB.

4. Operation and use.**4.1. Overload or short circuit of the PSU output (SCP on).**

The AUX output is equipped with an electronic protection. If power supply is loaded with current exceeding I_{MAX} . (load 110% ÷ 150% of PSU power), current and voltage are automatically limited. Voltage at output is restored automatically after overload is removed.

In case of the short-circuit to the AUX, BAT output, or incorrect connection of the battery, the fuse F_{BAT} in the battery circuit becomes permanently damaged and the restoration of the voltage at the BAT output requires the replacement of the fuse.

4.2. Dynamic battery test.

The PSU runs a battery test every 5 minutes. It is done by a momentary output voltage reduction and voltage measurement at the battery terminals. A failure is indicated when voltage drops below approx. 12,2 (24,4) V

4.3 Maintenance.

Any and all maintenance operations may be performed following the disconnection of the PSU from the power supply network. The PSU does not require performing any specific maintenance measures, however, in the case of significant dust rate, its interior is recommended to be cleaned with compressed air. In the case of a fuse replacement, use a replacement of the same parameters.

**WEEE LABEL**

Waste electrical and electronic equipment must not be disposed of with normal household waste. According to European Union WEEE Directive, waste electrical and electronic equipment should be disposed of separately from normal household waste.

CAUTION! The power supply unit is adapted for cooperation with the sealed lead-acid batteries (SLA). After the operation period they must not be thrown but recycled according to the applicable law.

Pulsar sp. j.

Siedlec 150,
32-744 Łapczyca, Poland
Tel. (+48) 14-610-19-45
e-mail: sales@pulsar.pl
http:// www.pulsar.pl

